



BO800RN
BO1200RN
PBO800RN
PBO400RN



Retrofit housing and retrofit handles
Bandeaux architecturaux et poignées ventouses

Range: Locking devices / **Gamme:** Verrouillage

INSTALLATION MANUAL
MANUEL D'INSTALLATION

BO800RN

Retrofit housing and retrofit handles

1] PRESENTATION OF THE PRODUCT

The BO800RN is an architectural handle which includes an advanced technology for magnetic locking. Ultra-fast installation and flexibility makes it an ideal product for retrofit to existing doors. Technology, ergonomics and performance ensures the BO800RN offers a major advantage over traditional electromagnetic locking. The patented profile fits in with the make up of the door, and tolerances within the product allow for door imperfections to be catered for. The BO800RN offers increased holding force, as 400Kg electromagnetic locks are used – 800Kg (where 2 magnets are included) and 1200Kg (where 3 magnets are included) increase the security and strength of the locking.

Technical Specification

- **Holding force:**
 - each magnet = 400Kg
 - 2.5 & 3m versions 800Kg (BO800RN) or 1200Kg (BO1200RN) 400mm version 400Kg (PBO400RN40cm) or 600mm version 800Kg (PBO800RN60cm)
- **Voltage: 12Vdc / 24Vdc.**
- **Current consumption per magnetic lock:** 560mA @ 12Vdc, 270mA @ 24Vdc.
- **Temperature range:** -20°C to +70°C.
- **Satin Anodised Aluminium** standard, optional RAL colour.
- **Composition: 2 elements**
 - 1 profiled handle for door (includes armatures)**
 - 1 section for locks (includes electromagnetic locks).**
- **Fixing:**
 - Wider fixing section (60mm)**
 - Profiled cover to match handle.**
- **Hidden fixings/connections – High Resistance to Vandalism.**
- **End caps for handle & section**

 -20°C to +70°C





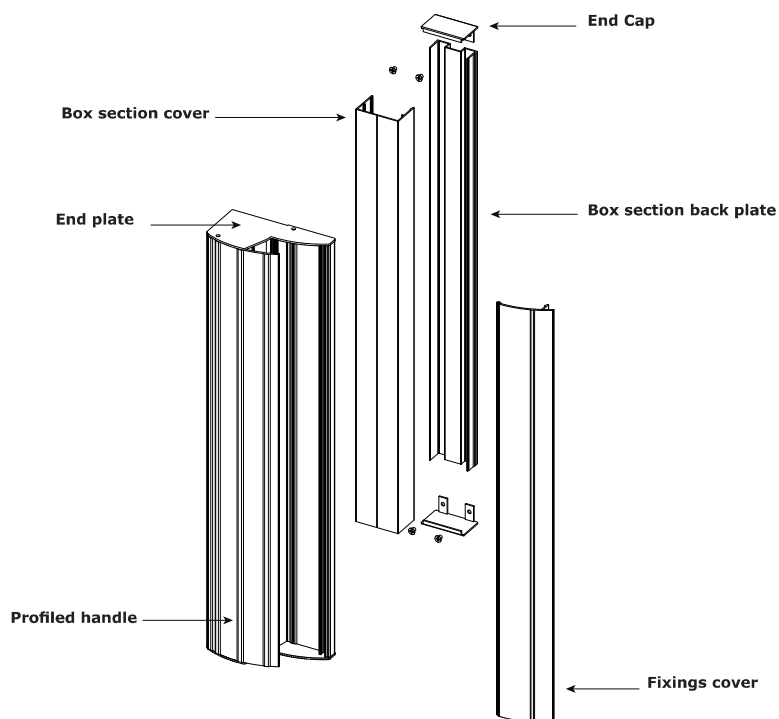
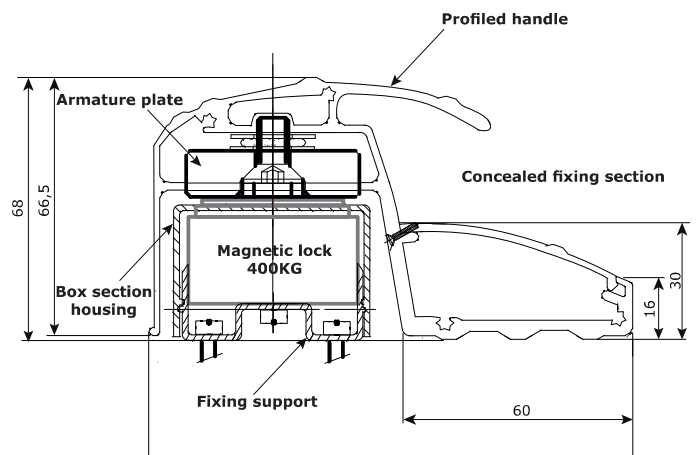

BO800RN

Retrofit housing and retrofit handles

Product Details

	BO800RN 2,5 m	BO1200RN 2,5 m	BO800RN 3 m	BO1200RN 3m	PBO800RN 60 cm	PBO400RN 40 cm	Housing
Description	Bandeau (2500 mm)	Bandeau (2500 mm)	Bandeau (3000 mm)	Bandeau (3000 mm)	Bandeau (600 mm)	Bandeau (400 mm)	-
Number of 400Kg magnets	2	3	2	3	2	1	■
Lock section with cover	1	1	1	1	1	1	-
Architectural handle with fixing cover	1	1	1	1	1	1	
End caps for handle	2	2	2	2	2	2	■
End caps for lock section	2	2	2	2	2	2	-
RAL colour (option)	■	■	■	■	■	■	-

Finishes

	Standard				
	(Ref. Product) AL	(Ref. Product) CH	(Ref. Product) BL	(Ref. Product) WH	(Ref. Product) BT
Description	Anodised aluminium (SAA)	Anodised champagne	RAL Black	RAL White	Untreated
Number of 400Kg magnets	■	■	■	■	-
Lock section with cover	■	■	■	■	■
Architectural handle with fixing cover	■	■	■	■	■
End caps for handle	■	■	■	■	■
End caps for lock section	■	■	■	■	■
RAL colour (option)	■	-	■	■	■
Cut-to-length service provided (optional)	■	-	■	■	-
Magnets & armatures supplied non-mounted (specify)	-	-	-	-	■

2] INFORMATION & RECOMMANDATIONS

Information

The electromagnets are pre-fitted within the lock section. The armature plates are pre-fitted within the architectural handle. Both sections are supplied with end caps.

Power Considerations

The handle is designed to house electromagnets with a holding force of 400Kg each. These units can be supplied by either 12Vdc or 24Vdc depending upon your preferred choice. The current required depends on the amount of electromagnetic locks, and the voltage chosen – please see Technical Specification, and ensure you have allocated sufficient power to correct performance. For example, the BO800RN2.5m (2.5m housing with 2 magnetic locks) would require:

- PSU12/2 or ARD2/12 at 12Vdc

PSU24/1 or ARD24 at 24Vdc.

General Advice

The 2 parts of the architectural housing are designed to be surface mounted on the door and frame, where they should be parallel when the door is closed. If there is a rebate, then it will be necessary to pack out the lower part to be parallel to the other. (Option of kit to provide 2, 4 or 10 mm packing).





Wiring

Plan your cable routes before commencing installation. We recommend a maximum distance of 10m from the power supply to the electromagnetic locks (to prevent volt drop). If the distance is greater, then make sure you have increased the cross section of the cable to compensate.

BO800RN

Retrofit housing and retrofit handles

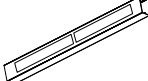
3] MOUNTING KIT

						
	Profiled handle with end caps	Profiled handle fixings cover	Box section back-plate	Box section cover	End caps	M4 x 6 round head screws
BO800RN (2,5 m)	1	1	1	1	2	4
BO1200RN (2,5 m)	1	1	1	1	2	4
BO800RN (3 m)	1	1	1	1	2	4
BO1200RN (3 m)	1	1	1	1	2	4
PBO800RN (60 cm)	1	1	1	1	2	4
PBO400RN (40 cm)	1	1	1	1	2	4

4] ASSEMBLY

Before commencing assembly, ensure you have the correct tools and accessories depending on the installation.

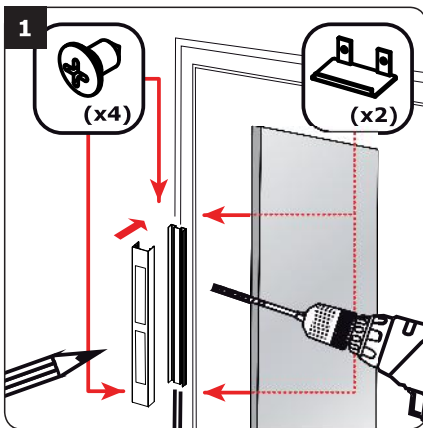

Position the box-section backplate, complete with pre-fitted electromagnetic locks, on to the door frame (or fixed door leaf if installing onto double doors) – ensure the positioning will allow for the architectural handle to close securely over the section. Once you are satisfied with the position, mark the vertical and horizontal holes, then drill as required. Take note of the cable entry holes, and feed the cables through. Fix the section into place, then wire the electromagnetic locks in accordance with the wiring schematic in Section 5. Fit the box section cover into place, fit the end caps and secure with the M4 screws provided.

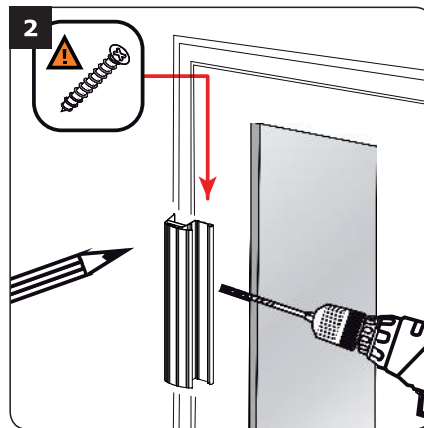

With the door closed, position the architectural handle onto the edge of the opening leaf of the door, ensuring the handle covers the box-section. Mark the vertical and horizontal holes, drill as required, then temporarily fix the handle leaving a small gap around the box section – check the alignment of the magnets in the box section with the magnets in the handle. Adjust if necessary, then once satisfied, secure the handle by completing the fixings.

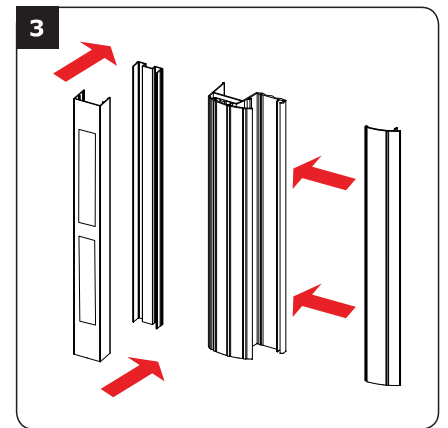

To finalise the assembly, tighten all fixings, and protect the handle fixing section by fitting the cover and end caps.

BO800RN

Retrofit housing and retrofit handles

5] WIRING SCHEMATIC

Example N°1: Exit button only (VHLD timer optional)

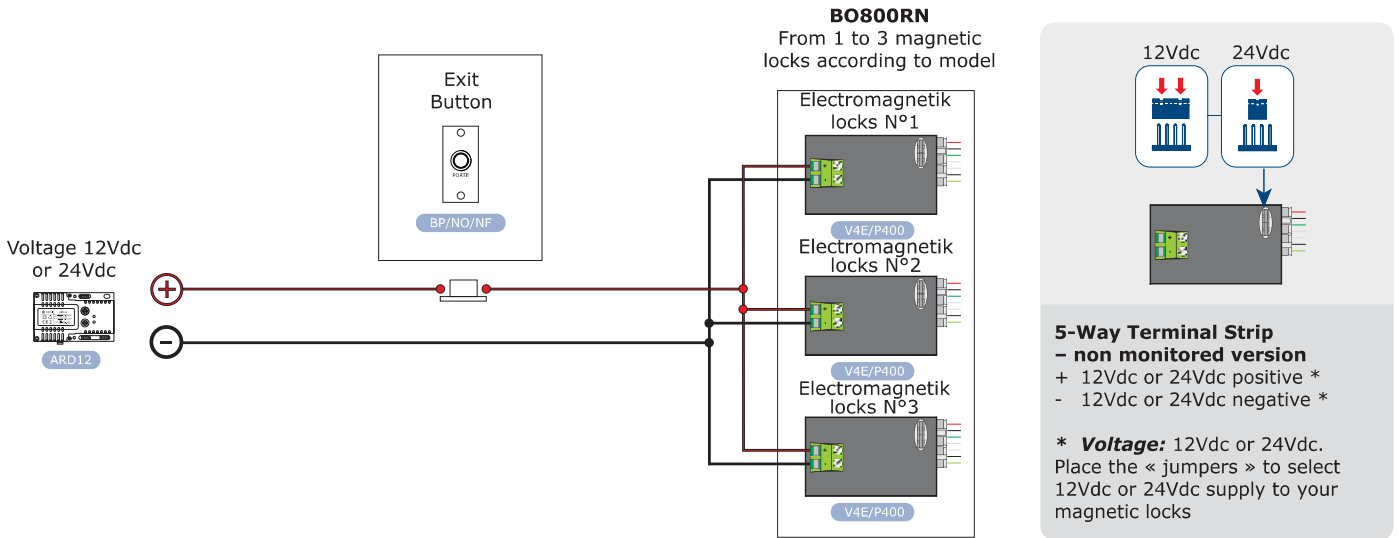

OPTIONS

Commande temporisée par TPV (1 par ventouses)

Important: When using a timer in circuit, please make note of the voltage used and ensure the timer can operate at the same voltage (example shows TPV)

Adjustable timer (0 to 20 seconds)



5-Way Terminal Strip – monitored version

- + 12Vdc or 24Vdc positive *
- 12Vdc or 24Vdc negative *
- NC Contact «Normally Closed»
- COM Common
- NO Contact «Normally Open»

* Voltage: 12Vdc or 24Vdc. Place the « jumpers » to select 12Vdc or 24Vdc supply to your magnetic locks.

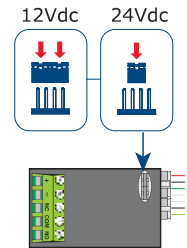

Example N°2: Access Control + Exit Button

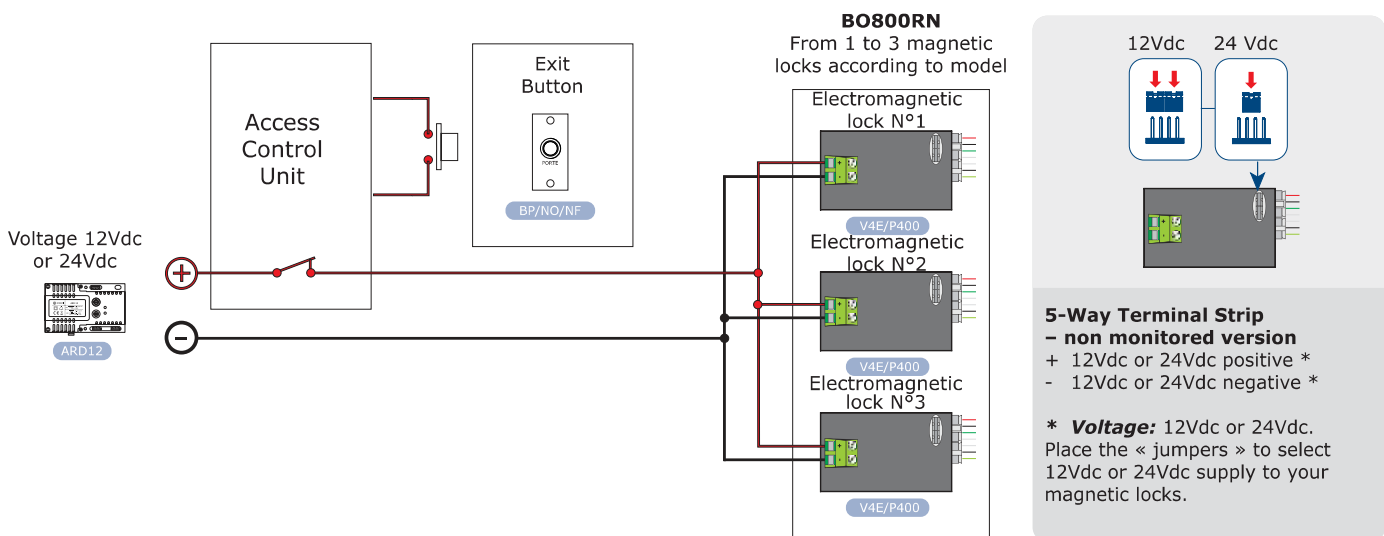

BO800RN

Retrofit housing and retrofit handles

6] NOTES

.....
.....
.....
.....
.....
.....
.....
.....
.....
.....
.....
.....
.....
.....
.....
.....
.....
.....
.....
.....
.....
.....
.....
.....
.....
.....
.....
.....
.....
.....
.....
.....
.....
.....
.....
.....
.....
.....
.....
.....
.....
.....
.....
.....
.....
.....
.....
.....
.....

Manufacturing Access Control since 1985



All the specifications on this document (photos, drawing, features and dimensions) could be changed without prior notice.
Toutes les indications mentionnées sur le présent document (photos, dessins, caractéristiques et côtes) sont susceptibles de modifications sans notification préalable.

CDVI (Headquarters/Siège social)
FRANCE
Phone: +33 (0)1 48 91 01 02
Fax: +33 (0)1 48 91 21 21

CDVI
AMERICAS
Phone: +1 (450) 682 7945
Fax: +1 (450) 682 9590

CDVI
BENELUX
Phone: +32 (0)5 662 02 50
Fax: +32 (0)5 662 02 55

CDVI
SWITZERLAND
Phone: +41 (0)21 882 18 41
Fax: +41 (0)21 882 18 42

CDVI
CHINA
Phone: +86 (0)10 87664065
Fax: +86 (0)10 87664165

CDVI
IBÉRICA
Phone: +34 936 916 551
Fax: +34 935 801 278

CDVI
ITALIA
Phone: +39 0331 97 38 08
Fax: +39 0331 97 39 70

CDVI
MAROC
Phone: +212 (0)22 48 09 40
Fax: +212 (0)22 48 34 69

CDVI
SWEDEN
Phone: +46 (0)31 760 19 30
Fax: +46 (0)31 748 09 30

CDVI
UK
Phone: +44 (0)1628 531300
Fax: +44 (0)1628 531003

DIGIT
FRANCE
Phone: +33 (0)1 41 71 06 85
Fax: +33 (0)1 41 71 06 86

TECHNO EM
FRANCE
Phone: +33 (0)4 42 96 58 73
Fax: +33 (0)4 42 96 45 77